

AVITEQ
Vibrationstechnik GmbH

**We drive
YOUR SUCCESS**





Delivering quality – OUR PACT

Over 70 years of experience, approximately 350,000 successful projects in vibration technology and almost 100 employees worldwide - these are the cornerstones upon which AViTEQ Vibrationstechnik GmbH drives its customers' success. Our accomplishments include:

- planning and realisation of process engineering systems based on vibration technology
- designing, producing and selling drive components and controllers for vibration plants
- all-around service for every AViTEQ and AEG system

Formerly an AEG enterprise, AViTEQ Vibrationstechnik GmbH has only been bearing its name since 1998, and is owner-operated since 2006. This is one of the reasons we hold business reputations in the highest regard. Our foundation is built on collaboration with trust, dependability and candour, within our company internally, as well as with our clients! Our employees have been with us for a long time, with an average of 17 years at the company. Our customers profit from our employees' dedication: the high level of their expertise and experience is monumental in resolving challenges in vibration technology.

Engineering, installation, management and specialist departments are located at company headquarters in Hattersheim, Germany. The world's best magnetic vibrators leave our assembly line at our Oberboihingen production facility near Stuttgart.

AViTEQ operates on a worldwide basis, with more than two-thirds of all products being sold abroad. Represented on all continents, AViTEQ's network includes subsidiaries, as well as commercial services and licensees. Regardless of your contact person within the network, everyone has one thing in mind: driving your success.

"Our
collaboration is built
on trust, reliability
and candour."

 **AViTEQ's Executive Board:**
Achim Eicke, Wolfgang and Björn Finger



Perfection is never found on the shelf IT DEVELOPS IN THE MIND

Conveying capacity, bulk density, grain size and product moisture, or necessary operations such as discharging, conveying, dosing, screening and cooling – each requires a specific design. Off-the-shelf solutions seldom provide maximum optimisation, which is exactly what you need to stand apart from your competition. That is why more than one-third of AVITEQ's employees are involved in developing custom solutions that consistently improve systems and components. Highly specialised engineers from the development, construction and engineering departments work as a close-knit team. The intensive exchange of clever ideas, expertise and extensive years of experience form the tools with which we drive your success!

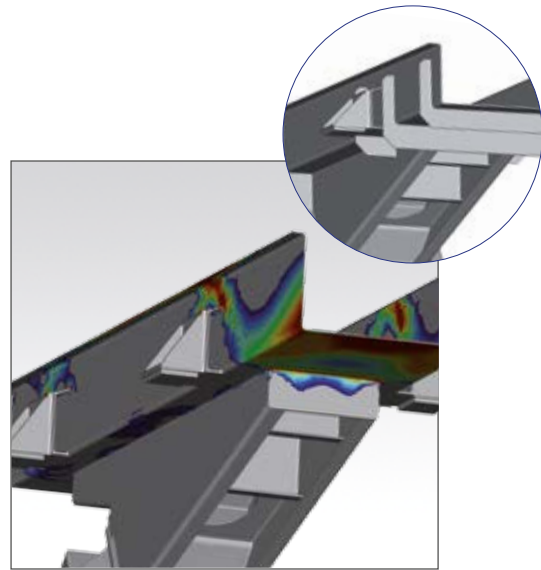

FINITE ELEMENT METHOD (FEM)

The Finite Element Method has proven to be exceptional in improving products and components.

AVITEQ relies on this state-of-the-art simulation process to consistently help detect hidden weaknesses and eliminate them. Thanks to FEM, we can confirm design reliability, as well as pass on cost savings due to these optimisations.

BULK MATERIAL DATABASE

Whether aerosil, cellulose, bauxite, quartz powder or xanthan gum, approximately 3,600 different bulk materials and their most important properties are stored in AVITEQ's bulk material database. This archive also hosts the results of experimental testing and a myriad of empirical values from experience. With almost 70 years' experience in materials handling technology, our engineers have compiled a knowledge reservoir of inestimable value in a concise format.

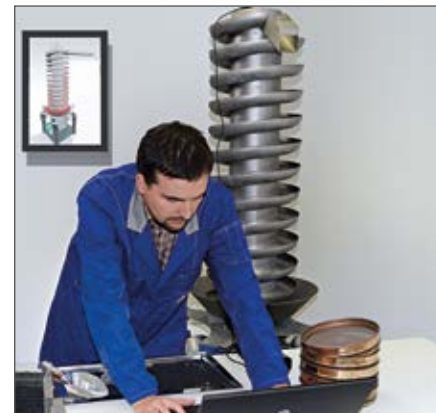

TECHNICAL CENTRE / BULK MATERIAL LAB

In our reconceptualised technical centre, comprised of 100 m² state-of-the-art space, we put our designs to the test. Here, we also examine specific performance requirements for our customers using their own bulk material. The bulk material lab is used for testing various bulk materials applied in order to ascertain their conveyability and screenability, for example, in practice. The performance data for bulk density, grain size distribution or moisture content can also offer numerous optimisation perspectives.

QUALITY

AVITEQ's facilities in Hattersheim and Oberboihingen are DIN ISO 9001 certified. Every internal operating process is subject to systematic monitoring by the respective accredited agency. We are also vigilant about the quality of our vendors, as well. Annually, our quality management department audits more than 80% of our suppliers according to DIN EN ISO 9001 standards.

In order to satisfy escalating international safety requirements, we provide relevant safety certificates such as ATEX, CSA and Gost-R for our systems and components. As a member of the European Hygienic Engineering & Design Group (EHEDG), we also satisfy the hygiene requirements within selected industries. AVITEQ is also a member of the VDMA and the DSIV.





Bulk materials have character. SO DO OUR SYSTEMS!

CUSTOM REQUIREMENTS

Each bulk material and application places specific requirements on a system. Whether conveying capacity, bulk density, grain size, or product moisture, there is a long list of significant factors that influence the design and planning of a conveying system. Moreover, industry-specific requirements or peculiarities also impact bulk materials, such as the electrostatic charging of dry plastic particles. High in demand are smart solutions with explosion-proof areas. Many years of experience and extensive application expertise are essential for such challenges.

BROAD BASED INDUSTRY EXPERTISE

For almost 70 years, AVITEQ engineers have been integral in the planning and design of vibration technology systems. We have been able to accumulate detailed knowledge in the following industries:

- Recycling, environment & glass
- Construction, quarries, pits, mining & cement
- Chemicals, plastics & pharmaceuticals
- Food & animal feed
- Steel production & foundry technology



RECYCLING, ENVIRONMENT, GLASS

Conditions: sharp-edged debris, glass shards and hot materials.

Hallmarks of AVITEQ systems:

- Extensive wear protection
- Protection against dust and dirt
- Precise dosage (e.g. sorting shards by laser)



CONSTRUCTION, QUARRIES, PITS, MINING, CEMENT

Conditions: most extremely hard, abrasive bulk materials and heavy exposure to dust.

Hallmarks of AVITEQ systems:

- Robust design
- Low-wear cladding
- Extremely durable



CHEMICALS, PLASTICS, PHARMACEUTICALS

Conditions: strict hygiene requirements, sensitive bulk materials, rigid rules.

Hallmarks of AVITEQ systems:

- Easy cleaning method
- Easy controller integration
- Design for explosion-proof areas (ATEX, CSA, IP)



FOOD, ANIMAL FEED

Conditions: strict hygiene requirements, sensitive bulk materials.

Hallmarks of AVITEQ systems:

- Easy cleaning method
- Product cooling or heating
- Gentle conveyance, maintenance-free or low-maintenance



STEEL PRODUCTION, FOUNDRY TECHNOLOGY

Conditions: extremely hard, abrasive bulk materials, high temperatures and high exposure to dust.

Hallmarks of AVITEQ systems:

- Rugged design
- Heat-resistant
- Low-wear cladding
- Immediate stoppage of the bulk materials (dosage)
- Good controllability



We deliver FUNCTIONALITY

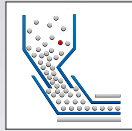

DISCHARGING FEEDING CONVEYING

HOPPER DISCHARGE UNIT

- Application closing, discharging, conveying and dosing mechanism in one unit
- Length up to 6,000 mm, width up to 2,500 mm
- Conveying capacity up to approx. 10,000 t/h

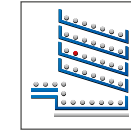

VERTICAL CONVEYING



SPIRAL CONVEYOR

- Gentle on bulk material, energy- and space-saving
- Conveyor height up to 8,000 mm with a spiral diameter of up to 1,500 mm
- Conveying capacity up to approx. 30 m³/h

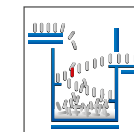

SORTING DOSING STORING

SMALL CONVEYOR

- Conveying and dosage of fine-grained, but not too bulky, mass materials
- Feeding and storing mass-produced parts
- Industry- and product-specific solutions
- Conveying capacity up to 45 m³/h, with individual drives up to max. 2,000 mm length or max. 600 mm width
- High conveying capacity with compact dimensions

PARTS CONVEYOR

- Sorting, feeding and storing mass-produced parts
- Custom solutions up to 600 mm cup diameter
- High conveying capacity in compact dimensions



TROUGH FEEDER

- Robust and flexible construction for conveying and dosage
- Length up to 9,000 mm; width up to 3,500 mm
- Conveying capacity up to approx. 1,000 m³/h



TUBULAR FEEDER

- Dust-proof and hygienic
- Length up to 9,000 mm; diameter up to 500 mm
- Conveying capacity up to approx. 100 m³/h



REVERSIBLE TUBULAR FEEDER/ REVERSIBLE TROUGH CONVEYOR

- Bulk material direction change without mechanical valve system
- Length up to 7,000 mm; width up to 1,200 mm
- Conveying capacity up to approx. 200 m³/h

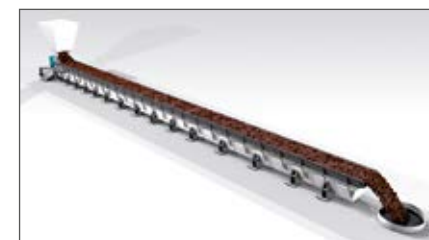

GUIDED TROUGH FEEDER

- Low construction height and suitable for hot bulk materials
- Length up to 22,000 mm; width up to 900 mm
- Conveying capacity up to approx. 180 m³/h



We deliver FUNCTIONALITY

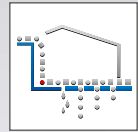

**SCREENING
CLASSIFYING
DEWATERING**

VIBRATING SCREENS

We supply numerous types of vibrating screens. The selection depends on the bulk material, the task desired (dewatering, screen classifying, screening) and the space available. Further options include: vibration screen, the vibration mode (elliptical, linear) and the drive used (magnetic vibrator, unbalance motor, unbalance exciter).

- Length up to 10,000 mm
- Width up to 4,000 mm
- Conveying capacity up to approx. 750 m³/h



DEWATERING SCREEN

- Dewatering up to 12% residual moisture (sand)
- Length up to 5,000 mm; width up to 2,800 mm
- Conveying capacity up to approx. 200 m³/h



CIRCULAR MOTION SCREEN

- Ideally suited for protective screening tasks
- Length up to 9,000 mm; width up to 4,000 mm
- Conveying capacity up to approx. 500 m³/h

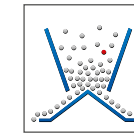

SPREADING

STREWING COVER/STREWING PLATE

- High strewing accuracy by means of magnetic vibrators, foodstuff-approved, hygienic design possible
- Spread up to 4,000 mm
- Strewing capacity from 1 to 1,000 litres of strewn material per hour per metre of spread

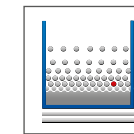

COMPACTING LOOSENING

VIBRATING TABLE

- For compacting
- Lengths up to 4,000 mm
- Widths up to 2,000 mm
- Load capacities up to 3,000 kg

HOPPER VIBRATOR

- For loosening
- Phenomenal shaking force in small dimensions
- Bunker diameter up to 4,000 mm
- Wall thicknesses up to 25 mm
- Vibration frequencies of 1,500 - 6,000 min⁻¹

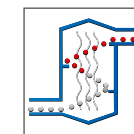

COOLING HEATING DRYING

VIBRATING FLUIDBED SYSTEMS AND HEAT EXCHANGE EQUIPMENT

- Cooling, heating or drying mechanism
- Wide range of models for optimum adaptation to existing processes, extremely gentle product handling



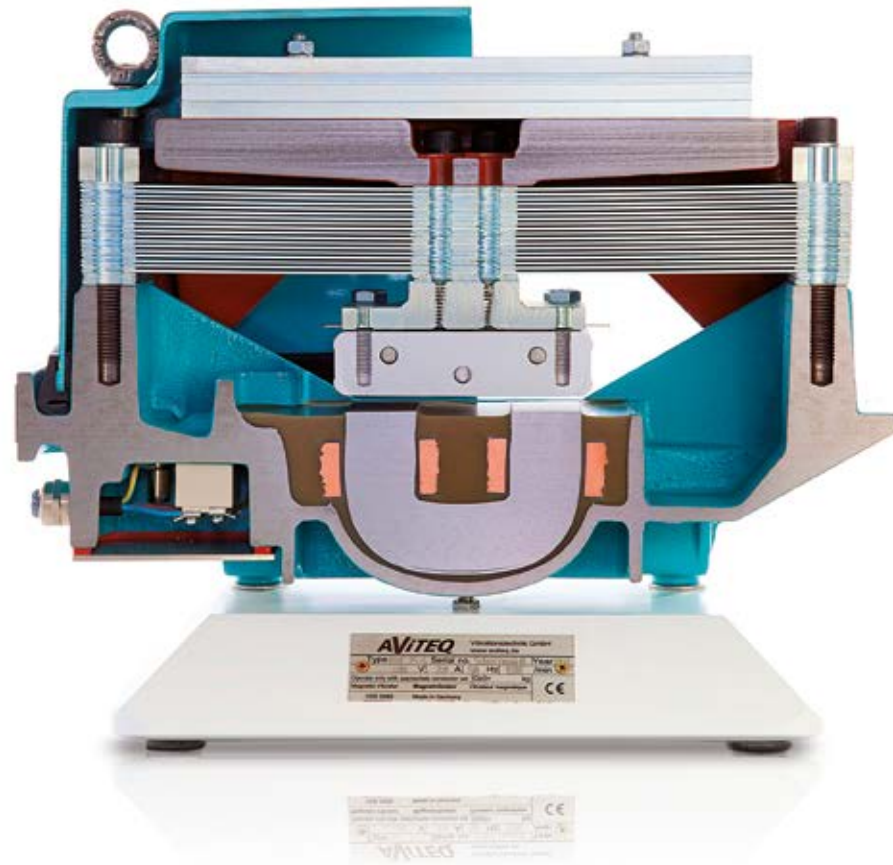

At the heart OF YOUR PLANTS

AVITEQ components are known throughout the world for their ruggedness and durability. This does not come by surprise. After all, we only use high-quality materials in our components. For instance, the magnetic vibrators' spring assemblies have a unique surface coating. Every coil and core of the magnetic vibrators is vibration- and dust-proof and cast in epoxy resin. The unbalanced motors' ball and roller bearings are generously dimensioned, and depending on the size, are produced with a permanent lubrication with relubrication options.

However, high-quality design not only equals durability. Extremely low maintenance costs, high levels of operational reliability, and thanks to intelligent design solutions, minor installation expenses make certain that AVITEQ components investments pay off over the long-term as well.



MAGNETIC VIBRATORS

AVITEQ magnetic vibrators can be variably controlled; flow at 100% output immediately upon activation; and stopping the flow of material upon deactivation in fractions of a second. They stand apart thanks to exceptionally long operating cycles and service life. Our range of products includes magnetic vibrators for:

- Flow rates of a few kg/h to several thousand t/h
- Use at ambient temperatures of -25 to +40 °C (special versions for lower and higher temperatures possible)
- Optional equipment with tropicalised insulation, explosion protection (e.g. ATEX)



UNBALANCE MOTORS

Designed specifically for continuous discharging and conveying over a longer distance, as well as screening and dewatering. High performance, operation cost-efficiency, as well as exceptional reliability and durability, are the most significant features of AVITEQ's unbalance motors.

- Working torque up to 2,800 hg/cm
- Centrifugal forces from 40 up to 119,000 N
- Useful weight up to 5,000 kg equipment tare weight
- Use at ambient temperatures of -20 to +55 °C
- Tropicalised design
- Optional equipment with explosion protection (e.g. ATEX, CSA, UL)

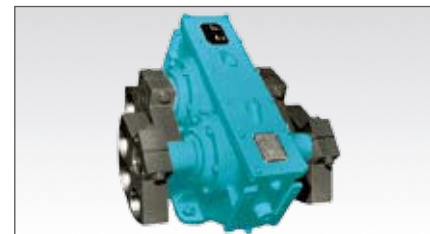

UNBALANCE EXCITERS

Preferably used on vibrating conveyors and screens with useful weight > 4,000 kg. In case of extremely heavy vibrating conveyors and screens, several unbalance exciters can be used parallel. Unlike others, they are exceptionally quiet, have a wide adjustment range and are extremely durable.

- Excitation force up to 424,000 N
- Working torque up to 15,000 kgcm
- Useful weight from 900 up to approx. 20,000 kg
- Use at ambient temperatures of -40 to +70 °C
- Explosion protection on request



PARTS CONVEYOR DRIVES

Feeding mass-produced parts piece by piece in a prespecified position in a magazine, a machine or an assembling device: this is what AVITEQ parts conveyors have been best known for in Europe for over 60 years. The "Frankfurter cup" still has meaning for a lot of people. The TF 280, our first parts conveyor, was originally introduced to the market in 1954. Countless derivatives of this original have been tailored to specific products and are still in use in many branches of industry today.

- Units for sorting, feeding and storing mass-produced parts
- Custom solutions up to a cup diameter of 600 mm
- High conveying capacity, compact dimensions



SMALL CONVEYOR DRIVES

Small conveyors are used for discharging, conveying, dosing, feeding and distributing fine-grained bulk materials and not too bulky mass-produced parts from storage containers. AVITEQ has been supplying these devices and drives as product-specific solutions in virtually every branch of industry for more than 60 years.

- Conveying capacity up to 45m³/h (with individual drives up to max. 2,000 mm length or max. 600 mm width)
- High conveying capacity, compact dimensions



CONTROLLERS & ACCESSORIES

AVITEQ provides an extensive range of controllers, braking units and speed control products, which are also applicable for third-party manufacturers as well. The standard units can be used in various ways and precisely optimised with a series of optional equipment items for specific applications. We supply:

- Vibtronic®-S controllers for controlling magnetic vibrators
- Vibtronic®-U braking units for controlled braking of unbalanced motors
- Vibtronic®-U frequency converters for the variable control of unbalanced motors and unbalanced exciters



"We are there
for you just in case
something jams!"

 The AViTEQ service team



Only when it comes to service ARE WE OLD-FASHIONED

AViTEQ machinery is known for its exceptional ruggedness and durability. Nonetheless, when used constantly, a machine can malfunction. Should this occur, professional support is required. The sooner the better, because malfunctions often mean system and process downtime, resulting in lost time and earnings.

Long queue times or incompetent service representatives on outsourced hotline services are the last thing one needs in such situations.

Unfortunately, this kind of „service“ is ever more frequent today, which is why AViTEQ is going in a completely different direction; a direction that could be described as "The Good Old-Fashioned Way." By this we mean:

- Replacement part support (24-hour delivery service for warehoused parts)
- Repair service (in-house and on-site)
- Qualified and experienced office and field service employees
- Direct-dial on-call phone service
- Expert assistance in case of malfunctions or problems
- Mobile service for professional support on site

...and as preventive measures:

- Check-ups
- Inspections

Negotiating. Selling. Forgetting. Not at AViTEQ.

Besides an extensive repair and replacement parts service for our drives and systems, our customer care includes support during installation and startup. Moreover, AViTEQ provides training and instruction for operating and maintenance personnel as services, too.

As a result, users know how to operate and care for the equipment, components and systems – making for optimum conditions for a long service life. After all, it is best if you never need our repair and replacement part support in the first place.



We support our AViTEQ and AEG brands.

Hotline - Technical Support:
Phone: +49 (0)6145/503-110
Fax: +49 (0)6145/503-452
Email: service@aviteq.de



Made by AViTEQ IN DEMAND WORLDWIDE



We are there for you, around the world, and in over 30 countries locally. Talk to us, become a customer, and find out exactly what quality and service Made by AViTEQ means. We always keep our contact information up-to-date for you at:

● www.aviteq.de ●



AViTEQ Vibrationstechnik GmbH

Im Gotthelf 16
D-65795 Hattersheim

Phone: +49 (0) 6145 503-0
Fax: +49 (0) 6145 503-200
Email: info@aviteq.de
www.aviteq.de